

## Room Air Conditioners - Fan Coils - Blowers

### Features:

- Auto Protector
- Continuous Duty, Air Over
- Energy Efficient \$
- Permanent Split Capacitor
- 1/2" Dia. Flatted Shafts
- CCWLE Rotation
- Sleeve Bearing
- Semi-Enclosed Construction
- 60 Hz

- Lugs available separately
- Use Kit No. 1327 - 1/4" Slot  
1328 - 3/4" Slot  
1329 - Length Adapter

OEM replacement for Chrysler, Sears, Whirlpool, Gibson, Carrier, Quiet Kool, Delco, Singer, American Standard, Fedders, Tappan, York and others.

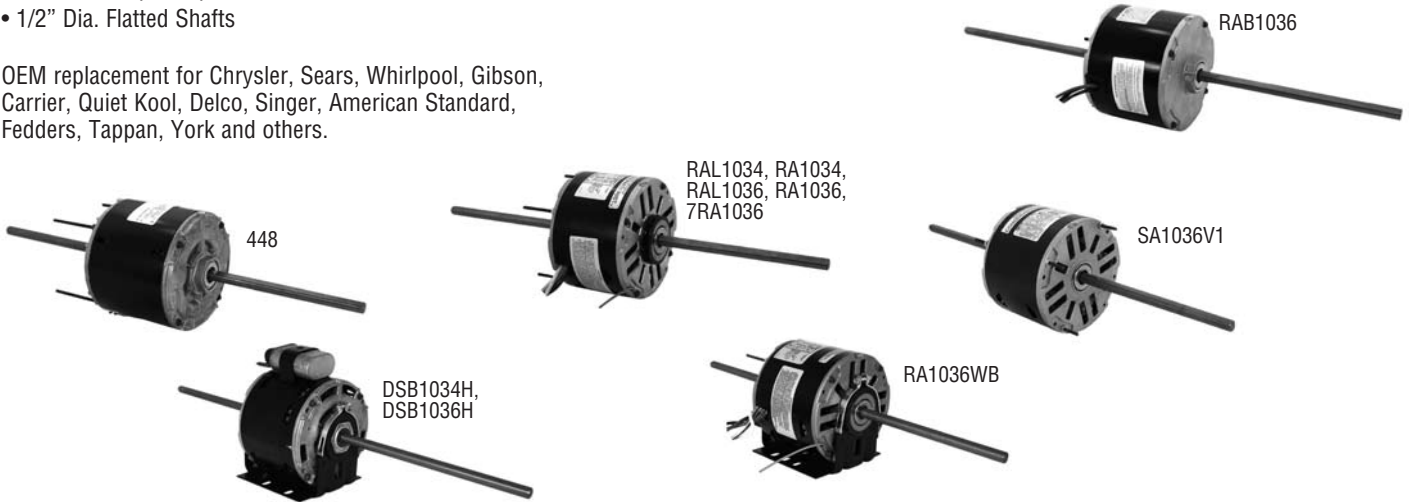

HP	RPM**	Speeds	Volts	Amps Rated	Stock Number	Capacitor	Dim. Ref.	Notes
1/3	1075	3	115	5.0	<b>RAL1036</b>	5MFD-370V	2	6,24,31,\$
1/3	1075	3	208-230	1.9	<b>RA1036</b>	5MFD-370V	3	24,29,\$
1/3	1075	3	208-230	1.9	<b>RA1036WB</b>	5MFD-370V	8	29,81,\$
1/3	1075	3	208-230	2.2	<b>SA1036V1</b>	5MFD-370V	4	31,\$
1/3	1075	3	230	1.9	<b>RAB1036</b>	5MFD-370V	6	31,118,\$
1/3	1075	3	230	3.1	<b>DSB1036H</b>	Included	7	31,81,\$
1/3	1075	3	277	1.9	<b>448</b>	7.5MFD-370V	5	1,31,\$
1/3	1075	3	277	1.9	<b>7RA1036</b>	7.5MFD-370V	5	24,31,\$
1/3	1625	3	115	4.0	<b>RAL1034</b>	5MFD-370V	1	6,24,31,\$
1/3	1625	3	208-230	2.0	<b>RA1034</b>	5MFD-370V	1	24,90,\$
1/3	1625	3	230	2.0	<b>DSB1034H</b>	Included	9	31,81,\$

### Notes:

1. Item to be discontinued when stock is depleted
6. 60/50 HZ
24. Mounting accessories packaged with motor
29. 60°C Ambient
31. 40°C Ambient
81. Includes base
90. 50°C Ambient
118. TEAO

\*\*Approximately 150 RPM difference between speeds.

Continues on next page

### Approximate Dimensions

Ref.	BM	FC	N	N1
1	4.61	20.00	7.39	8.00
2	4.86	20.00	7.89	7.25
3	4.61	20.00	8.14	7.25
4	4.11	20.00	7.95	7.94
5	4.61	20.00	7.64	7.75
6	4.49	13.49	4.00	5.00
7	4.36	19.36	7.50	7.50
8	4.61	20.11	6.50	9.00
9	4.49	19.49	7.50	7.50

Minimum R = BM + 3/4"  
Maximum R = BM + 2"

